

DO NOT SCALE

This drawing has been produced by DLT Engineering in accordance with the instructions of the client for their sole and specific use.  
 DLT Engineering shall not be liable for the use of any information contained on this drawing for any purpose other than that for which it was specifically prepared and provided.  
 Should there be any doubt regarding the interpretation of any information given on this drawing, enquiries should be directed to DLT Engineering at the address given below before executing such part of the works.

Copyright © DLT Engineering Ltd.

NOTES

**SPECIFICATION**

SAFE WORKING LOAD	46 TONNES
No. OF 18mm STRANDS	3
STRAND CABLE O.D.	74mm
TOTAL WEIGHT OF FIXED ANCHOR INCLUDING ANCHOR BLOCKS, GRIP ASSEMBLIES, ETC. BUT EXCLUDING SHACKLE.	36 kg

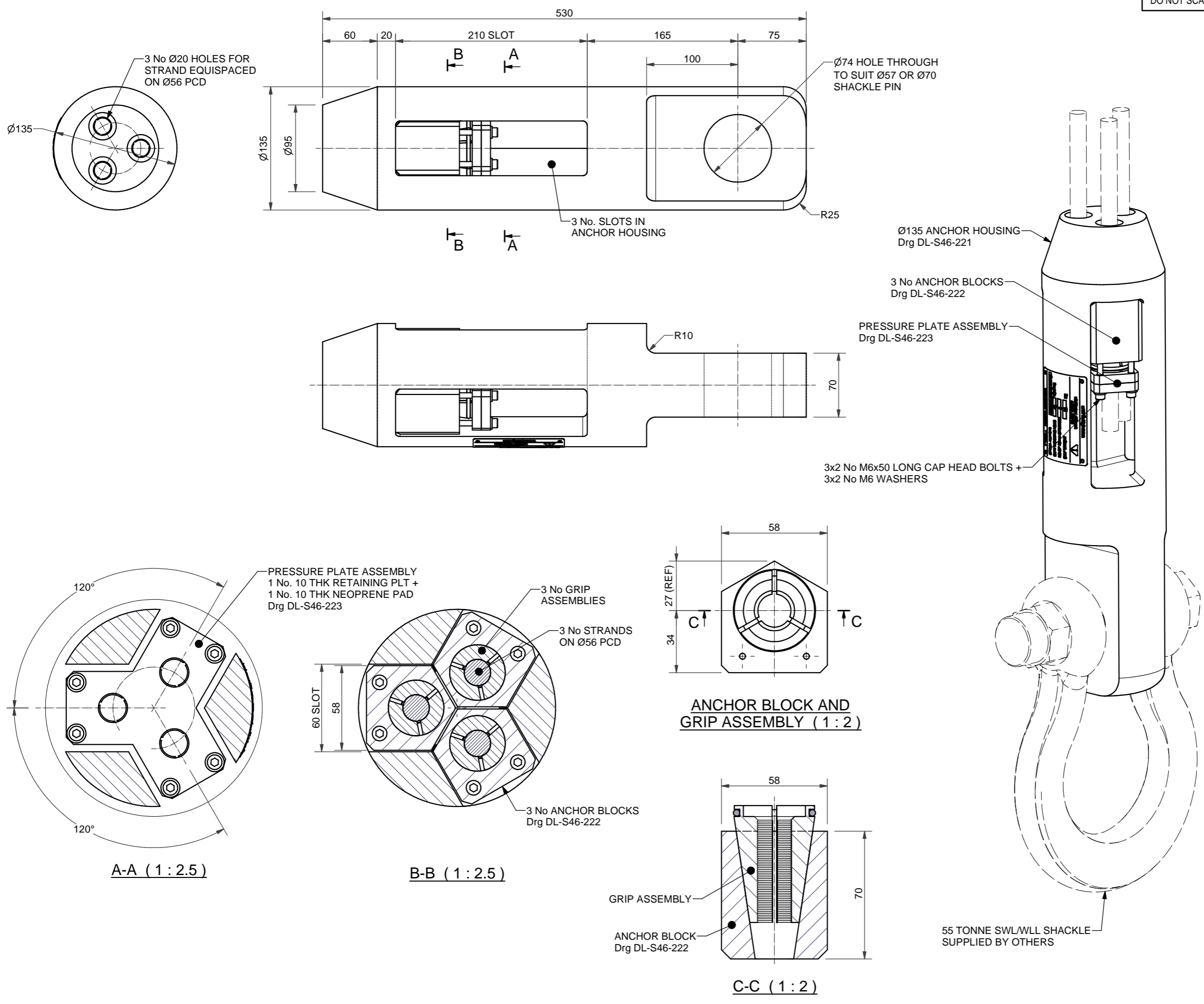

N2	12.08.19	INF	MODEL AND TITLE BLOCK UPDATED	AW	SAB
I1	02.04.15	INF	GENERAL REVISIONS	AW	SAB
A	25.02.09	PRE	PRELIMINARY	JJ	SAB
Rev	Date	Status	Description	By	Chkd

**DLT Engineering**  
 International House  
 Midland Road, Higham Ferrers  
 Northamptonshire, NN10 8DN  
 United Kingdom  
 Tel: +44 (0) 1933 319133  
 www.dlteng.com

Project  
**DL-S46 STRAND JACK SYSTEM**

Drawing Title  
**BULLET FIXED ANCHOR TYPE 2  
 135 DIA ANCHOR HOUSING  
 GENERAL ARRANGEMENT**

Design Eng:	NP	Checking Eng:	SAB
Drawn by:	AW	Project Eng:	SAB

Scales (At A3) AS SHOWN  
 Drawing Status  
**INFORMATION**

Original Drawing size: A3  
 Drawing No. **DL-S46-202** Rev. **N2**